



## Automatic Bird Feeder Prototype Design Using Esp8266 Microcontroller Based On Android

Aji Nurrohman<sup>1</sup>, Berliyanto<sup>2\*</sup>, Sigit Wibisono<sup>3</sup>, Surya Darma<sup>4</sup>, Wibisono<sup>5</sup>,  
Leni Devera Asrar<sup>6</sup>, Triyono Budi Santoso<sup>7</sup>

<sup>1,2,3,4,5</sup> Institut Teknologi Budi Utomo

\*E-mail: [berliyanto@gmail.com](mailto:berliyanto@gmail.com)

Received : December 2022

Accepted : February 2023

Published : April 2023

### Abstract

To make life easier for pet owners, a product titled "Prototype Design of Automatic Bird Feeding Tool with Android-Based NodeMcu ESP8266 Microcontroller" was created. When a pet owner is unable to control his pet's diet, a tool that is connected to the internet is required to make it simpler for the pet owner to monitor remotely using an Android device. The system device is made up of numerous components, including a NodeMcu ESP8266 microcontroller, a servo motor for opening and closing a feed door, and an RCT DS3231 digital timer for output. A Blynk application connected to the gadget is installed on the pet owner's smartphone and allows for remote monitoring.

**Keywords:** Automatic Feed, RCT DS3231, Blynk, NodeMcu ESP8266

### Introduction

Computer technology has been developed quickly with digital technology. Currently, a wide range of electronic equipment and computer systems operate quickly. Operating these electronic equipment will benefit considerably from this assistance. Feeders that can be operated automatically or remotely are one area of research that is currently being developed. using a smartphone in hand, you may feed birds using this multimedia device, which also has a few other features. Humans have been inspired by technological advancements to solve every issue that arises in their environment and reduce the amount of effort that is now required. Microcontrollers are an example of a developing technology. An electronic chip known as a microcontroller can process digital data in accordance with instructions written in assembly language. Arduino is a microcontroller that is currently being developed; it is used. Microcontroller Minimum System Design is a product developed by Arduino, which is open source. using a bootloader software encoded in the modified C programming language, which communicates with the microcontroller using Arduino. Because most people find keeping birds to be simple in terms of maintenance and care, many bird keepers have made it one of the most common hobbies in their local communities.

This bird food is being created with the intention of addressing the problem that many bird owners face, which is a lack of time to feed their flock. This problem is exacerbated when an owner is on the road for an extended period of time. As and when they can, owners usually feed the birds. How to consistently feed pet birds without stopping what you're doing. People who frequently travel large distances and frequently leave their own pets at home have a great need for a bird feeder that can be operated remotely via an android smartphone. Through his smartphone, the owner will find this tool to be more convenient. The Esp8266 NodeMcu will be used as a feed control and an android device on a smartphone as a feed remote control tool by the author in order to assist the creation of this utility. A wifi module called the Esp8266 is frequently used in Internet of Things (IOT) applications including controlling actuators and reading sensors [1][4]. People are still needed to fill the provided bird feed container as part of the work system employed to create this product. After receiving a command from the user via Android remotely, the bird feed container will execute the command to start supplying food through the Esp8266 NodeMcu.



### Methodology

The Taman Malaka Utara neighborhood in East Jakarta, where manual feeding arrangement activities are still being done, is the location of the author's investigation for this paper. This automatic feed mechanism is meant by the phrase "manual method" by.1) System with a board to open and close.2) Employing bird food. It is intended for this activity to be implemented in stages, starting with preparation, observation, and drafting a research report. In general, the author can summarize this research as shown in the flow diagram below.

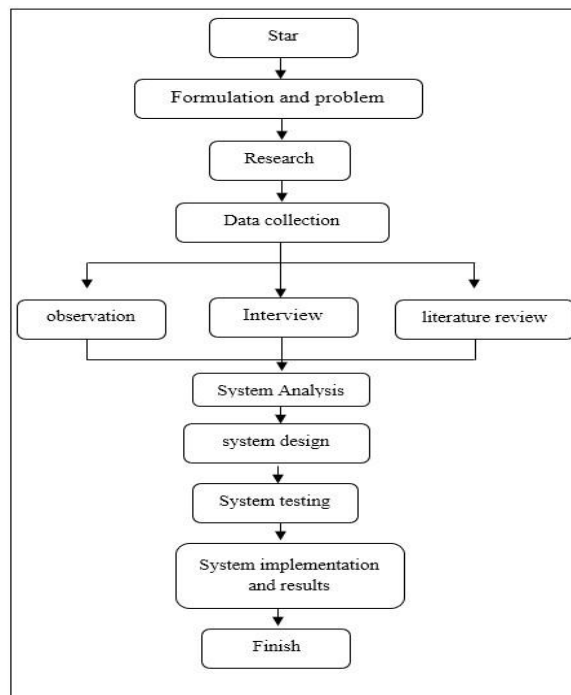

Figure 1. Research Framework

### Prototype Development Stage

The process of building the prototype is broken down into multiple steps, as shown in the following diagram:

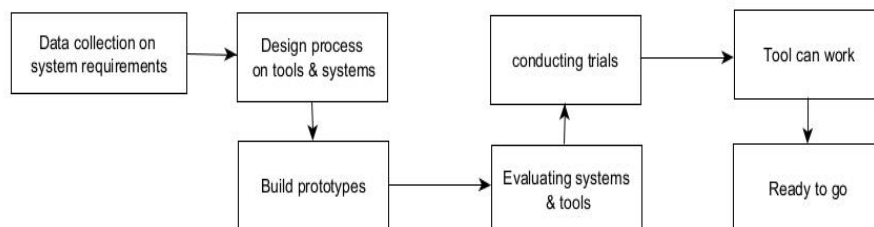

Figure 2: Prototype Construction

Prototyping, according to Ogedebe, is a way of developing software that creates a physical representation of how a system functions and acts as an early version of the system [3].

**Block diagram for a complete tool set**

It is well known that the NodeMcu Esp8266 microcontroller serves as the primary micro for processing input and output data in this autonomous feeding apparatus overall. Real-time clock data is used as the system's input. The real-time clock serves as a timer for the feeder. The NodeMcu Esp8266's output comprises of a number of circuits, including an LCD to display data from each and servo motors to automatically open and close the feed door.

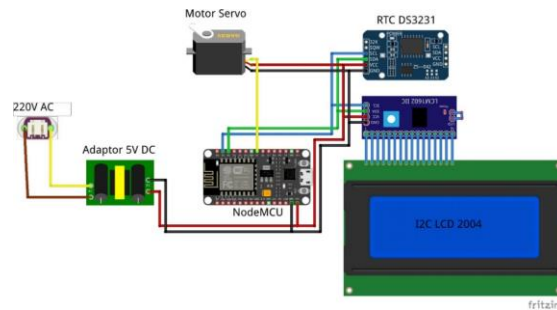

Figure 3: Device circuit

A microcontroller, in Sumardi's definition, is a digital electronic device that contains inputs, outputs, and control with programs that can be added to or removed in a particular way [5]. A microcontroller functions by reading and writing data.

**Results**

**Program for Tools at Work Design of Flowcharts**

The automatic opening and closing of the feed door is the basis of this NodeMCU Esp8266-based automatic bird feed tool design. Along with showing time information on the LCD panel. Real time clock input is required for this tool to function. Several circuits, including an LCD and a servo motor, are included in the NodeMCU Esp8266's output. The feed door is automatically opened and closed thanks to the servo motor.

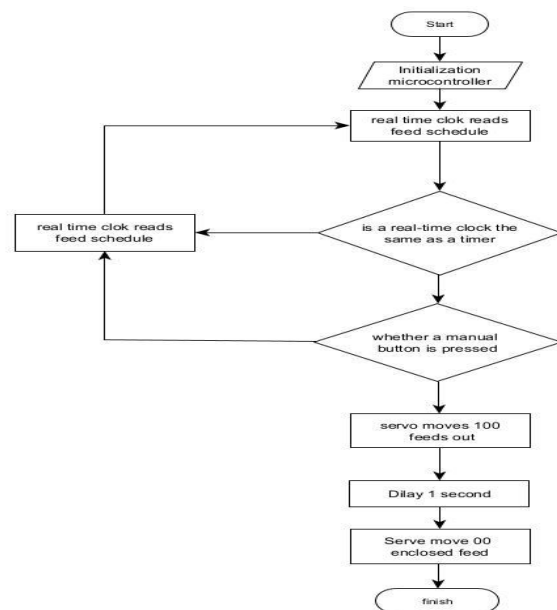

Figure 1: Flowchart of Tool Work Program

### Application view for the arduino IDE

The Arduino IDE application, which uses programming language to run a tool in accordance with the desired command entered into the Arduino IDE application using the programming language, is currently displayed as follows. The Arduino IDE's main display is as follows:

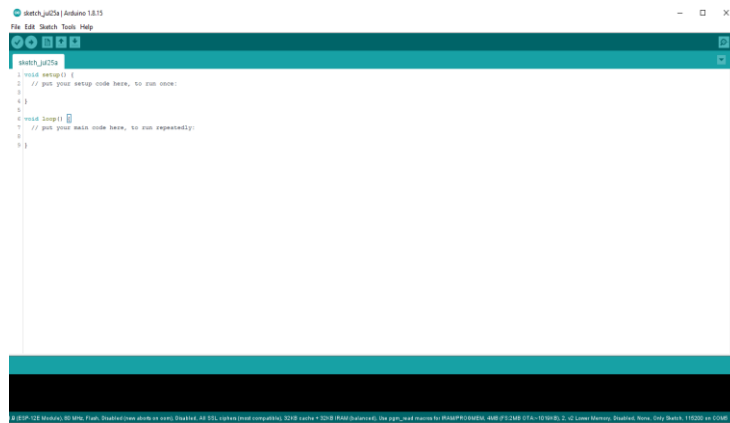

Figure 2: Initial View of the Arduino IDE Application

### Display of automatic feed door control device

The author illustrates a small automatic feed door control mechanism in a cage with a drawing or design in this discussion.

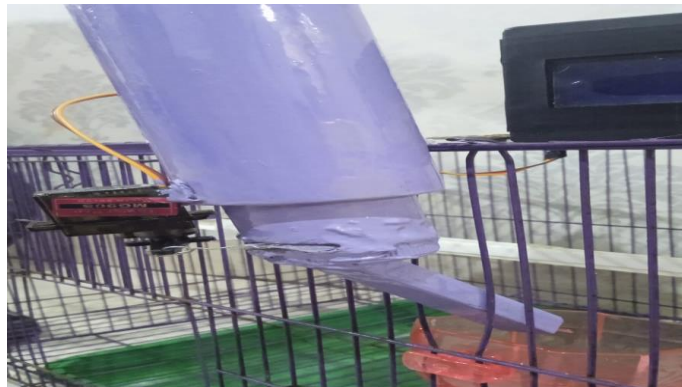

Figure 3: Miniature Design of Automatic Feed Door Control Device

### Coding for the tool

ESP8266 NodeMCU

This code enables the NodeMCU ESP8266 to connect to the Internet through WiFi[2]. The programming language is as follows:



## References

- [1] Junaidi, A. (10 Agustus 2015). *Internet Of Things, Sejarah, Teknologi dan Penerapan*. Bandung: Universitas Widyatama.
- [2] Wicaksono, M. F. (2017). *IMPLEMENTASI MODUL WIFI NODEMCU ESP8266*. Bandung: Unikom.
- [3] Ogedebe, P.M.,& Jacob, B.P. (2012), *Software Prototyping: A Strategy to*
- [4] Use When User Lacks Data Processing Experience. *ARPN Journal of Systems and Software*. VOL. 2, NO.6 , 2012, from <http://citeseerx.ist.psu.edu/viewdoc/summary?doi=10.1.1.675.391>
- [5] Sumardi, (2013). *MIKROKONTROLER Belajar AVR dari Nol*. Yogyakarta: GRAHA ILMU.